

#### 5.4 Entering To The Programming Mode, Changing and Saving Parameter

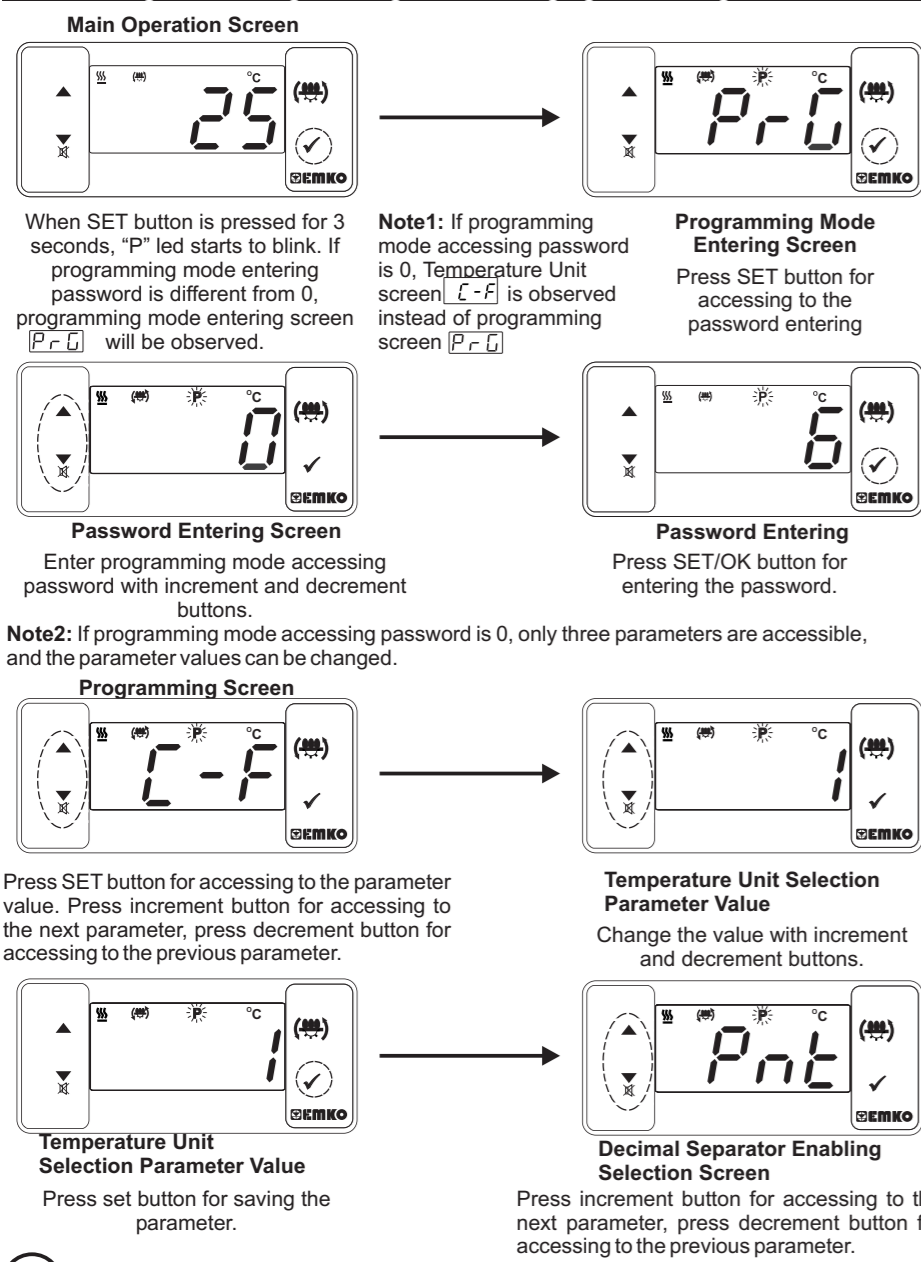

#### 6. Failure Messages in ESM 3721HT Hatcher Controller

1- [5 b r] Screen Blinking Temperature Sensor failure. Sensor connection is wrong or there is no sensor connection. While this message shown on this display, if buzzer function selection [b u f] is 3,5,7 or 8 internal buzzer starts to operate.

#### 7. Manual Start of Egg Tray Rotator Operation with Engine Button

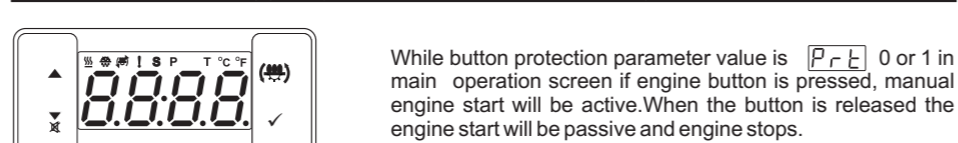

#### 8. Auto Tune Metod

Auto Tune method is used for determining PID parameters used by the device.

**Starting Auto Tune (Limit Cycle Tuning) Operation by the user :**

- Adjust temperature control on/off or PID parameter ([P-o]=1)
- Adjust auto tune selection parameter ([R t U n]= [ 4 5 3 ])
- "T" led is activated and auto tune process is started.

If Auto Tune operation is finished without any problem, the device saves the new PID coefficients, calculated using the previously found "T" and "B" values, to memory and continue to run. [R t U n] parameter is adjusted [ \_ \_ \_ ] automatically.

**Cancelling Auto Tune (Limit Cycle Tuning) operation :**

- 1- If sensor breaks;
- 2- If auto tune operation can not be completed in 8 hours;
- 3- If user adjusts [R t U n] parameter [ \_ \_ \_ ];
- 4- During auto tune operation if the user changes the temperature control from pid to on/off;
- 5- If process set value is changed while auto tune operation is being performed;

Auto tune is canceled. "T" led becomes inactive. Then, without doing any changes in PID parameters, device continues to run with previous PID parameters.

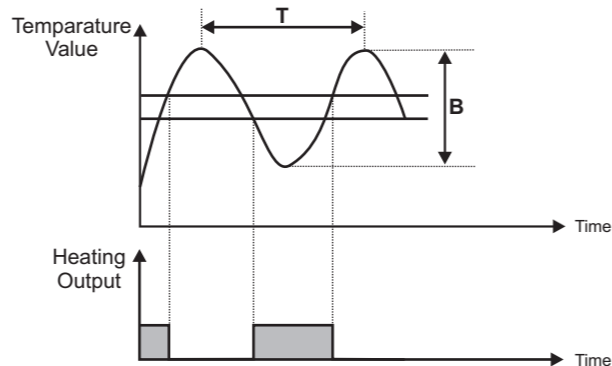

#### EMKO

### Hatcher Controller

### ESM-3721HT 77x35 DIN Size



#### ESM-3721HT 77 x 35 DIN Size Digital, ON / OFF Hatcher Controller

- 4 Digits Display
- PTC Input
- 3 Output
- Heating Control Output
- Egg tray rotator Output
- Alarm Control Output
- Selectable Temperature Control (ON / OFF or PID)
- Auto-Tune PID
- Set value boundaries
- Manual Start of tray rotator from front panel
- Alarm parameteraters
- Adjustable internal buzzer according to the alarm situations
- Password protection for programming mode,
- Having CE mark according to European Norms

Instruction Manual. ENG ESM-3721 01 V01 03/14

#### 1. Preface

ESM 3721HT series Hatcher controllers are designed for controlling hatcher process. Device can be used easily with PID or On-Off control form and manual start of egg tray rotator properties.

#### 1.1 Environmental Ratings

- Operating Temperature : 0 to 50 °C
- Max. Operating Humidity : 90% Rh (non-condensing)
- Altitude : Up to 2000 m.
- Forbidden Conditions:  
Corrosive atmosphere  
Explosive atmosphere  
Home applications (The unit is only for industrial applications)

#### 1.2. General Specifications

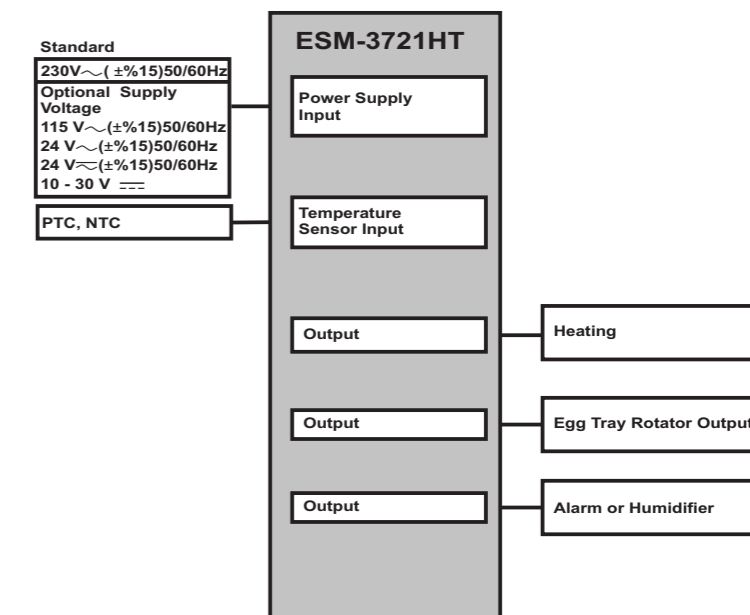

#### 9. Specifications

<b>Device Type</b>	: Hatcher Controller
<b>Housing&amp;Mounting</b>	: 76 mm x 34.5 mm x 71 mm Plastic housing for panel Panel cut out is 71 x 29 mm.
<b>Protection Clas</b>	: NEMA 4X (Ip65 at front, Ip20 at rear).
<b>Weight</b>	: Approximately 0.2 Kg
<b>Environmental Ratings</b>	: Standart, indoor at an altitude of less than 2000 meters with none condensing humidity.
<b>Storage / Operating Temperature</b>	: -40 °C to +80 °C / -30 °C to +80 °C
<b>Storage / Operating Humidity</b>	: 90 % max. (None condensing)
<b>Installation</b>	: Fixed installation
<b>Overvoltage Category</b>	: II.
<b>Pollution Degree</b>	: II, office or workplace, none conductive pollution
<b>Operating Conditions</b>	: Continuous
<b>Supply Voltage and Power</b>	: 230V~ (±%15) 50/60Hz - 1.5VA : 115V~ (±%15) 50/60Hz - 1.5VA : 24V~ (±%15) 50/60Hz - 1.5VA : 24V~ (±%15) 50/60Hz - 1.5VA : 10-30V= - 1.5W
<b>Temperature Sensor Input</b>	: PTC or NTC
<b>NTC input type</b>	: NTC (10 kΩ @25 °C)
<b>PTC input type</b>	: PTC (1000 Ω @25 °C)
<b>Accuracy</b>	: ± 1 % of full scale for thermoresistance
<b>Sensor Break Protection</b>	: Upscale
<b>Sampling Cycle</b>	: 3 samples per second
<b>Control Form</b>	: ON / OFF or PID
<b>Relay Outputs</b>	: 5 A@250 V~ at Resistive Load (Heating Output) : 3 A@250 V~ at Resistive Load (Alarm and Egg tray rotator output)
<b>Display</b>	: 14 mm Red 4 digit LED Display
<b>LED Displays</b>	: S (Yellow), P (Yellow), °C (Green), °F (Green), Alarm (Red), Egg Tray Rotator Output (Red), Heating Output (Red),
<b>Internal Buzzer</b>	: ≥83dB
<b>Approvals</b>	: GOST-R, CE

#### 10. Other Informations

ESM-3721 (77x35 DIN Size)	A	B	C	D	E	/	F	G	H	/	U	V	W	Z
<b>A Power Supply Voltage</b>	2	24V~ (±%15) 50/60Hz - 1.5VA	3	24V~ (±%15) 50/60Hz - 1.5VA	4	115V~ (±%15) 50/60Hz - 1.5VA	5	230V~ (±%15) 50/60Hz - 1.5VA	8	10 - 30 V= - 1.5W				
<b>BC Input Type</b>	12	PTC (Not-1)												
<b>E Heating Output</b>	1	Relay Output ( 5 A@250 V~ at Resistive Load, 1 NO )	2	SSR Driver Output ( Maximum 30mA, Maximum 15V )										
<b>FG Alarm or Humidifier Output</b>	1	Relay Output ( 3 A@250 V~ at Resistive Load, 1 NO )												
<b>HI Egg Tray Rotator Output</b>	1	Relay Output ( 3 A@250 V~ at Resistive Load, 1 NO )												
<b>V Temp. Sensor which is given with ESM-3721</b>	0	None	1	PTC-M6L40.K1.5 (PTC Air Probe with 1.5 mt silicon cable)	2	PTCS-M6L30.K1.5.1/8" (PTC Liquid Probe 1.5 mt silicon cable)	3	NTC-MSL20.K1.5 (NTC Sensor, thermoplastic moulded with 1.5 m cable for cooling application)	4	NTC-M6L50.K1.5 (NTC Sensor, stainless steel housing with 1.5 m cable for cooling application)	9	Customer		

All order information of ESM-3721HT Hatcher Controller are given on the table at above. User may form appropriate device configuration from information and codes that at the table and convert it to the ordering codes. Firstly, supply voltage then other specifications must be determined. Please fill the order code blanks according to your needs.

Please contact us, if your needs are out of the standards.  
**Note-1:** If input type is selected PTC or NTC (BC= 12, 18), Temperature sensor is given with the device. For this reason, if input type is selected as PTC, sensor type (V= 0, 1 or 2) or if input type is selected as NTC, sensor type (V= 0, 3 or 4) must be declared in ordering information.

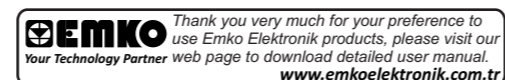
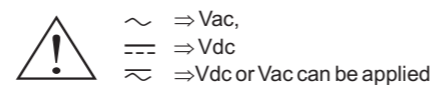

#### 1.3 Installation

A visual inspection of this product for possible damage occurred during shipment is recommended before installation. It is your responsibility to ensure that qualified mechanical and electrical technicians install this product.

If there is danger of serious accident resulting from a failure or defect in this unit, power off the system and separate the electrical connection of the device from the system.

The unit is normally supplied without a power supply switch or a fuse. Use power switch and fuse as required.

Be sure to use the rated power supply voltage to protect the unit against damage and to prevent failure. Keep the power off until all of the wiring is completed so that electric shock and trouble with the unit can be prevented.

Never attempt to disassemble, modify or repair this unit. Tampering with the unit may results in malfunction, electric shock or fire.

Do not use the unit in combustible or explosive gaseous atmospheres.

During putting equipment in hole on the metal panel while mechanical installation some metal burrs can cause injury on hands, you must be careful.

Montage of the product on a system must be done with it's fixing clamps. Do not do the montage of the device with inappropriate fixing clamp. Be sure that device will not fall while doing the montage.

It is your responsibility if this equipment is used in a manner not specified in this instruction manual.

#### 1.4 Warranty

EMKO Elektronik warrants that the equipment delivered is free from defects in material and workmanship. This warranty is provided for a period of two years. The warranty period starts from the delivery date. This warranty is in force if duty and responsibilities which are determined in warranty document and instruction manual performs by the customer completely.

#### 1.5 Maintenance

Repairs should only be performed by trained and specialized personnel. Cut power to the device before accessing internal parts.

Do not clean the case with hydrocarbon-based solvents (Petrol, Trichlorethylene etc.). Use of these solvents can reduce the mechanical reliability of the device. Use a cloth dampened in ethyl alcohol or water to clean the external plastic case.

#### 1.6 Manufacturer Company

**Manufacturer Information:**  
Emko Elektronik Sanayi ve Ticaret A.Ş.  
Demirtaş Organize Sanayi Bölgesi Karanfil Sk. No:6 16369 BURSA/TURKEY  
Phone : +90 224 261 1900  
Fax : +90 224 261 1912  
**Repair and maintenance service information:**  
Emko Elektronik Sanayi ve Ticaret A.Ş.  
Demirtaş Organize Sanayi Bölgesi Karanfil Sk. No:6 16369 BURSA/TURKEY  
Phone : +90 224 261 1900  
Fax : +90 224 261 1912

#### 2. General Description

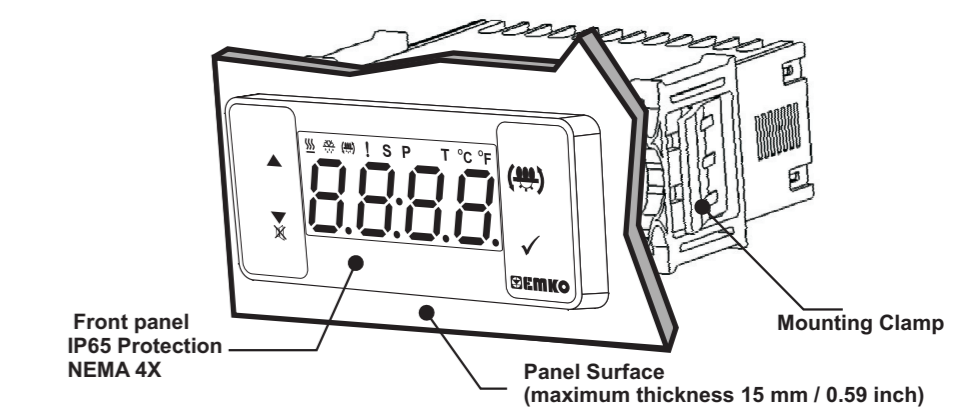

#### 2.1 Front View and Dimensions of ESM-3721 Hatcher Controller

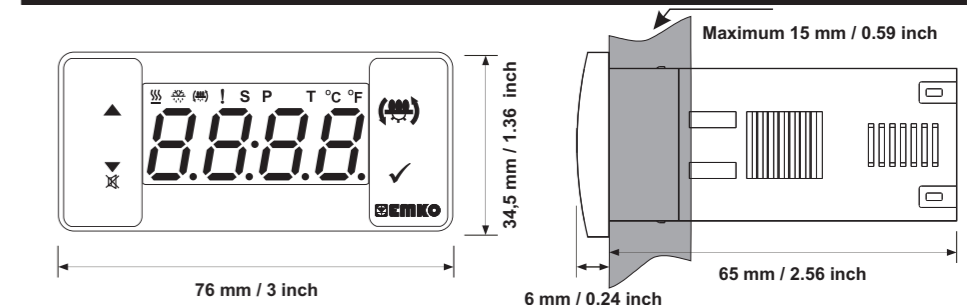

#### 2.2 Panel Cut- Out

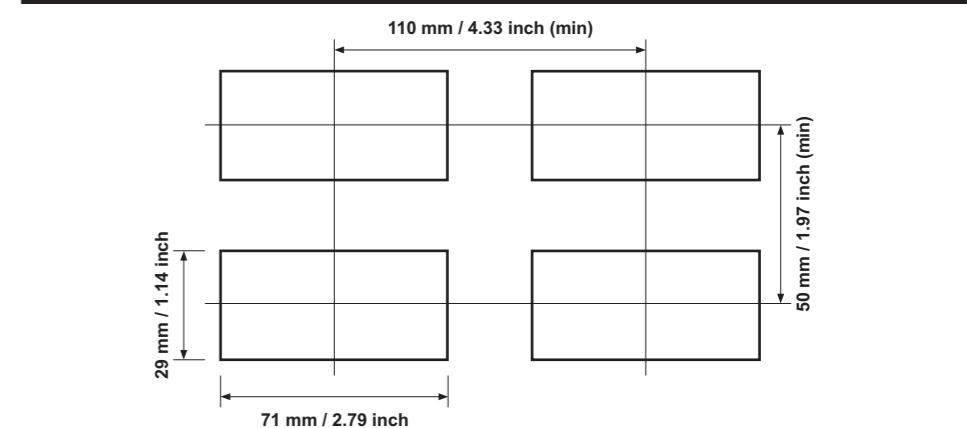

### 2.3 Panel Mounting and Removing

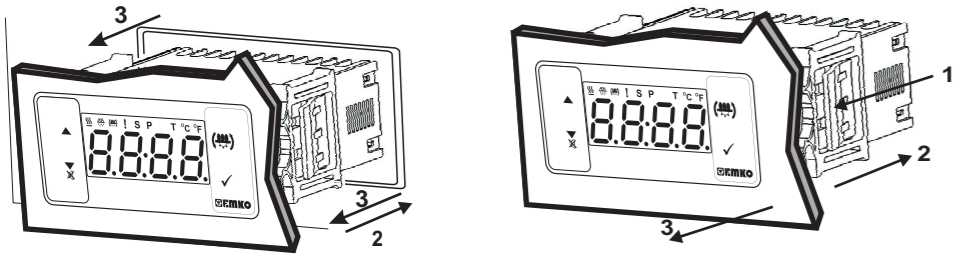

1-Before mounting the device in your panel, make sure that the cut-out is of the right size.  
2-Insert the device through the cut-out. If the mounting clamps are on the unit, put them before inserting the unit to the panel.  
3-Insert the mounting clamps to the fixing sockets that located left and right sides of device and make the unit completely immobile within the panel.

1-Pull mounting clamps from left and right fixing sockets.  
2-Pull the unit through the front side of the panel.

Before starting to remove the unit from panel, power off the unit and the related system.

### 3. Electrical Wiring Diagram

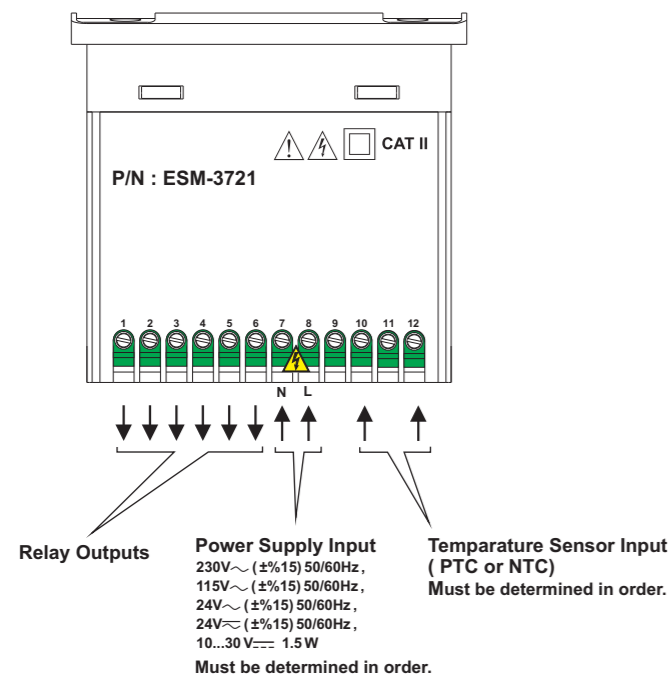

### 3.1 Supply Voltage Input Connection of the Device

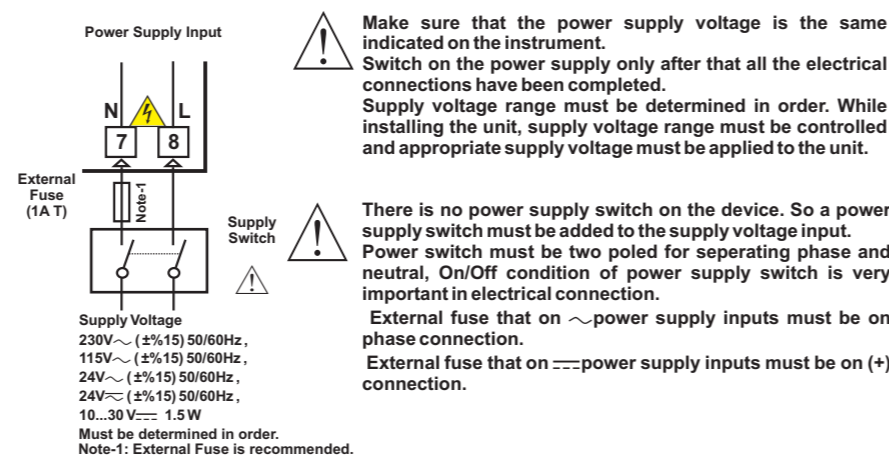

### 3.2 Device Label and Connection Diagram

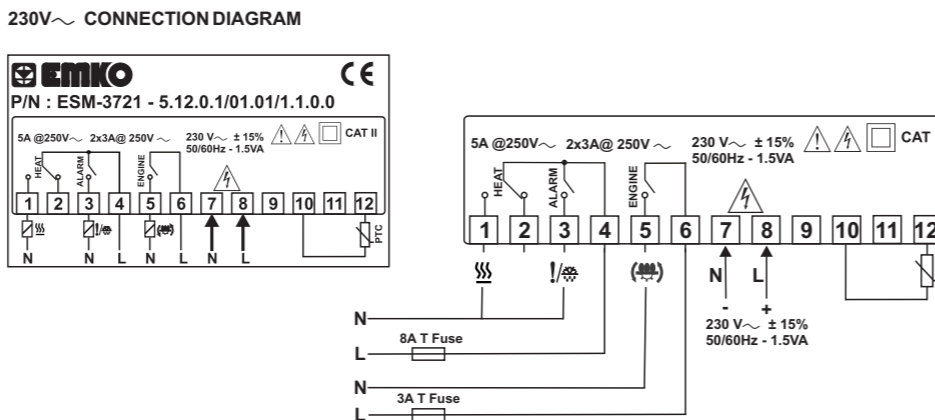

### 5.1 Programming Mode Parameter List

- P** PID - Proportional Control Parameter ( Default = 50 )  
This parameter value can be adjusted form 0 to 100.
  - I** PID - Integral Parameter ( Default = 1000 )  
This parameter value can be adjusted form 0 to 3600.
  - d** PID - Derivative Parameter ( Default = 250 )  
This parameter value can be adjusted form 0 to 3600.
  - t** PID - Period Parameter ( Default = 1 )  
This parameter value can be adjusted form 1 to 50 second.
  - hSt** Hysteresis Parameter for Temperature ( Default = 0.1 °C )  
From 1 to 10°C , PTC (0°C, 100°C)  
From 1 to 18°F, PTC (32°F, 212°F)  
From 0.1 to 10.0°C, PTC (0.0°C, 100.0°C)  
From 0.1 to 18.0°F, PTC (32.0°F, 212.0°F)  
In ON/OFF control algorithm, temperature value is tried to keep equal to set value by opening or closing the last control element. ON/OFF controlled system, temperature value oscillates continuously. Temperature value's oscillation period or amplitude around set value changes according to controlled system. For reducing oscillation period of temperature value, a threshold zone is formed below or around set value and this zone is named hysteresis.
  - SUL** Minimum Temperature Set Value Parameter ( Default = 10.0°C )  
Temperature set value can not be lower than this value. This parameter value can be adjusted from minimum value of device scale to maximum temperature set value parameter **SUh**.
  - SUh** Maximum Temperature Set Value Parameter ( Default = 40.0 °C )  
Temperature set value can not be greater than this value. This parameter value can be adjusted from minimum temperature set value parameter **SUL** to maximum value of the device scale.
  - oFt** Temperature Sensor Offset Parameter ( Default = 0.0 )  
From -10 to 10°C , PTC (0°C, 100°C)  
From -18 to 18°F, PTC (32°F, 212°F)  
From -10.0 to 10.0°C, PTC (0.0°C, 100.0°C)  
From -18.0 to 18.0°F, PTC (32.0°F, 212.0°F)
  - ndt** Time of Automatic Egg Tray Rotator ( Default = 00:00 )  
This parameter value can be adjusted form 00:00 to 99:00 minute/second.
  - ndP** Repeat cycle of Automatic Egg Tray Rotator ( Default = 00:00 )  
This parameter value can be adjusted form 00:00 to 24:00 hour/minute.
  - Lou** Alarm or Humidifier Output Function Selection Parameter ( Default = 3 )  
 Alarm is inactive  
 Alarm-Temperature sensor failures.  
 Alarm-Temperature or Temperature sensor failures.  
 Humidifier Output
- Note : if Lou parameter value is 3, Hdt and HdP parameters are observed.
- hdt** Time of Humidifier ( Default = 00:00 )  
This parameter value can be adjusted form 00:00 to 99:00 minute/second.

- hdP** Repeat cycle of Humidifier ( Default = 00:00 )  
This parameter value can be adjusted form 00:00 to 24:00 hour/minute.
- Note : if Lou parameter value is 2, Temperature Alarm parameters are observed.
- RLS** Temperature Alarm Function Selection Parameter ( Default = 0 )  
 Process High alarm selected.  
 Process Low alarm selected.  
 Deviation Band alarm selected.  
 Deviation Range alarm selected.
  - RSt** Temperature Alarm Set Parameter ( Default = 50.0 °C )  
This parameter value can be programmed between temperature minimum alarm set **RvL** parameter and temperature alarm set maximum **RvH** parameter.
  - RLh** Temperature Alarm Hysteresis Parameter ( Default = 0 )  
This parameter value can be adjusted form 0 to %50 of the device scale.
  - RvL** Alarm Set Minimum Parameter ( Default = Minimum Value of Device Scale )  
If temperature alarm is active, this parameter value can be adjusted from minimum value of device scale to temperature alarm set maximum parameter value **RvH**.
  - RvH** Alarm Set Maximum Parameter ( Default = Maximum Value of Device Scale )  
If temperature alarm is active, this parameter value can be adjusted from temperature alarm set value parameter **RvL** to maximum value of the device scale.
  - RdL** Temperature Alarm On Delay Time Parameter ( Default = 0 )  
Temperature Alarm On Delay Time can be defined with this parameter. It can be adjusted from 0 to 99 minutes.
  - Rpd** Temperature Alarm Delay After Power On Parameter ( Default = 0 )  
When power is first applied to the device, this time delay must be expired for activation of temperature alarm. It can be adjusted from 0 to 99 minutes.
  - bvF** Buzzer Function Selection Parameter ( Default = 0 )  
 Buzzer is inactive.  
 Buzzer is active during temperature alarm  
 Buzzer is active during Temperature sensor failures.  
 Buzzer is active during Temperature sensor failures or temperature alarm.
  - bon** Buzzer Active Time ( Default = ---- )  
If buzzer function selection parameter value **bvF** = 0, this parameter is not observed. Buzzer active time can be define with this parameter. It can be adjusted from 1 to 99 minutes. When this parameter is 1, if decrement button is pressed, ---- is observed. In this condition buzzer is active till buzzer silence button is pressed.
  - PrL** Button Protection Parameter ( Default = 0 )  
 There is no protection.  
 Temperature set value can not be changed.  
 Manual engine start is not available.  
 Temperature set value can not be change and Manual engine start is not available.
  - PRs** Programming Mode Accessing Password ( Default = 0 )  
It is used for accessing to programming mode. It can be adjusted from 0 to 9999. If it is 0, password is not entered for accessing to the parameters. If password is '12' only **hSt** Can be accessible.

### 4. Front Panel Definition and Accessing to the Menus

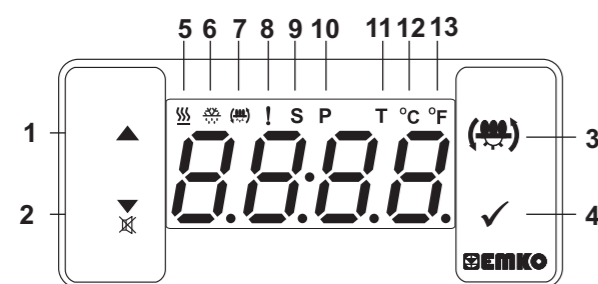

#### BUTTON DEFINITIONS

- 1. Increment Button :**  
\*\* It is used to increase the value in the Temperature and Humidity Set screens and Programming mode.
- 2. Decrement, Silencing Buzzer Button :**  
\*\* It is used to decrease the value in the Set screen and Programming mode.  
\*\* It is used to silence the buzzer.
- 3. Manual Start of Egg Tray Rotator Operation Button :**  
\*\* In the main operation screen, if this button pressed engine starts. When the button is released the engine start will be passive and engine stops.
- 4. Set Button :**  
\*\* In the main operation screen; if this button pressed, set value will be displayed. Value can be changed using increment and decrement buttons. When Set button pressed again, value is saved and returns back to main operation screen.  
\*\* To access the programming screen; in the main operation screen, press this button for 3 seconds.  
\*\* It is used to saving value in the Set screen and programming screen.

#### LED DEFINITIONS

- 5. Heating Output Led :**  
\*\* This led indicates that heating output is active.
- 6. Humidifier Output Led :**  
\*\* This led indicates that Humidifier output is active.
- 7. Egg Tray Rotator Output Led :**  
\*\* This led indicates that Egg Tray Rotator Output is active.
- 8. Alarm led :**  
\*\* It is active when alarm statuses.
- 9. Set led :**  
\*\* Indicates that device is in Set value changing mode.
- 10. Program led :**  
\*\* Indicates that device is in programming mode.
- 11. Auto Tune led :**  
\*\* This led indicates that Auto Tune operation is active.
- 12. Celcius led :**  
\*\* Indicates that device is in °C mode.
- 13. Fahrenheit led :**  
\*\* Indicates that device is in °F mode.

### 5. Changing and Saving Temperature Set Value

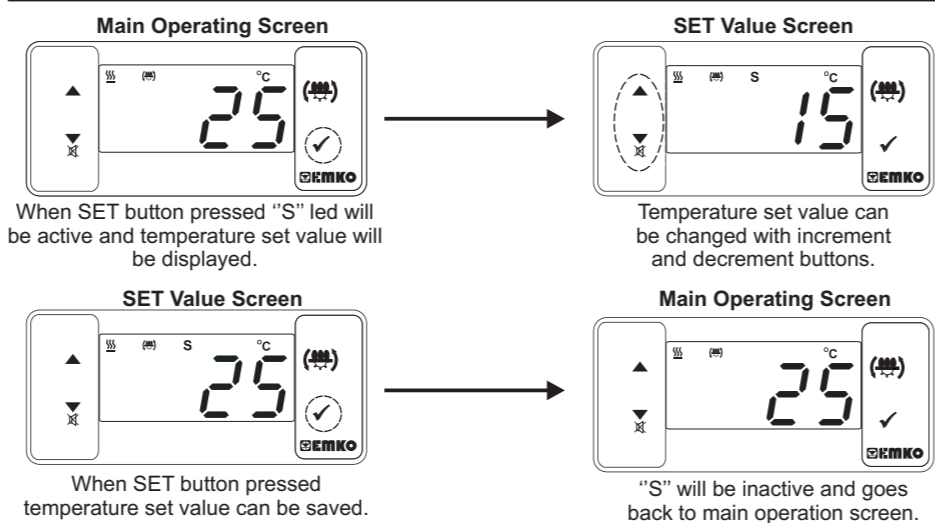

**Temperature set value parameter ( Default = 37.4°C )**  
Temperature set value, can be programmed between minimum temperature set value **SUL** and maximum temperature set value **SUh**.

If no operation is performed in temperature set value changing mode for 5 seconds, device turns to main operation screen automatically.

#### 5.1 Programming Mode Parameter List

- C-F** Temperature Unit Selection Parameter ( Default = 0 )  
 °C selected.  
 °F selected.
  - Pnt** Decimal Separator Enabling Parameter ( Default = 1 )  
 None.  
 Only Temperature parameters with decimal separator.
- Note : When value of C-F or Pnt parameters are changed, the values of Set, hSt, SuH, SUL, oFt, Ast, ALh, AUL and Auh parameters should be changed accordingly.
- P-o** Temperature Control Selection Parameter On/Off or PID ( Default = 0 )  
 On - Off selected.  
 PID selected.
- Note: If this parameter is select 0, PID parameters will be not observed. If this parameter select 1, **hSt** parameter will be not observed.
- RLtun** Auto Tune (Limit Cycle Tuning) Selection Parameter ( Default = 0 )  
 Device does not do (Limit cycle Tuning) operation.  
 Device does operation.

### 5.2 Alarm Output Graphics of ESM-3721 Hatcher Controller

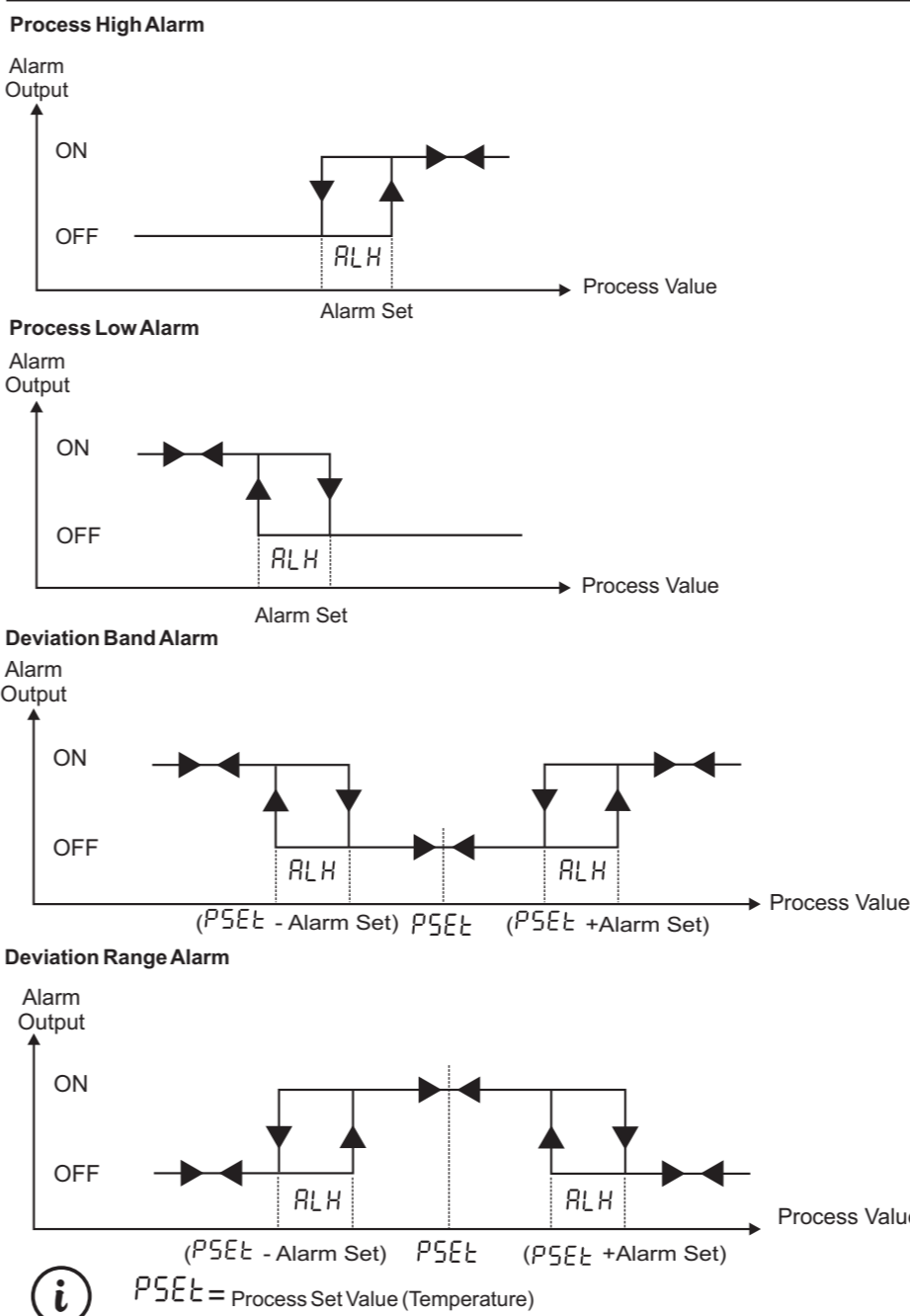

### 5.3 Egg Tray Rotator and Humidifier Output Operation Graphics of ESM-3721

